

Powerful. Beautiful.  
**Excellence · Innovation**

IDD21190  
IDD22190  
IDD24190



**Shanghai Panelmate Electronics Co., Ltd.**

19" SXGA Industrial Monitor



## Features

- Display type: 10.1",10.4",12.1",12.2",15",15.6",17",18.5",19",21.5",24",27"
- Front panel/back cover: Aluminium-magnesium alloy
- Front panel/Rear: IP65 / IP20
- Screen Type: Single point resistive touchscreen, Multi-point capacitive touchscreen, Non-touch screen
- OS:Win XP, Win7,Win10/Win11, Win CE, LINUX
- Interface: DVI, HDMI, VGA video interface, 2xUSB
- DC 9~36V wide volts range
- R1(IDD-LINK),Long distance USB signal output, support 50m
- R2(IDD-LINK4),Video and USB are transmitted via a single CAT6 network cable, Transmission distance up to 100m

## Namely Rule

IDD2XXXXHP-R1-xxK-xxxx

- Industrial monitor
- Series code
- 21: Resistance screen
- 22: Capacitive screen
- 24: Non-touch screen
- Display size
- (Support 15.6" 18.5" )High resolution screen
- (Support 21.5" ,24" ,27" )Vertical screen

- Customized code(blank)
- Numbers of extension buttons(standard:00K)
- Signal interface
- Blank: DVI + VGA + HDMI + USB
- R1 : DVI + VGA + HDMI + RJ45 (IDD-LINK)
- R2 : RJ45 (IDD-LINK4)

## Specifications

Model	IDD21190&IDD22190&IDD24190	
<b>Routine</b>	Control button	Set contrast ratio and luminance via OSD at the back cover
	Housing	Front panel & back cover:Aluminium-magnesium alloy,Grounding isolation protection
	Mounting	Embedded,Wall-mounted,VESA ,Desktop
	Rear I/O	VGA & DVI & HDMI & USB
<b>Power</b>	Input Voltage	DC 9~36V
	Power	14W
<b>Physical</b>	Dimension (WxHxD/mm)	428 x 372 x 57.5 (16.85" x 14.65" x 2.26")
	Open Size (WxH/mm)	412 x 358 (16.22" x 14.09")
	Net Weight(kg)	5.15
<b>LCD</b>	Display type	19" SXGA TFT
	Resolution	1280 x 1024
	Colors	16.7M
	Active Area (WxH/mm)	376.32mm x 301.06mm (14.82" x 11.85")
	Backlight	LED
	MTBF(Hour)	30000hrs
	Pixel Pitch (HxV)	0.294 x 0.294
	Luminance(cd/m2)	250
	Contrast Ratio	1000: 1
	Viewing Angle	(L)85 / (R)85 / (U)80 / (D)80
<b>Touchscreen</b>	Touch Type	Single point resistive touchscreen & Multi-point capacitive touchscreen & Non-touch screen
	Light Transmission	>85%
	Controller	USB interface
	Driver Support	Windows XP, Windows 7, Windows 8, Windows 10/11, Linux, CE
	Multi-touch	10 points
	Surface Hardness	Resistive touchscreen: Mohs' Number >= 3H;Capacitive touchscreen: Mohs' Number 7H
<b>Environment</b>	Operating Temperature	0 ~ 50°C
	Storage Temperature	-20 ~ 60°C
	Relative Humidity	5 ~ 95% (Non condensation)
	Shock	Operating 10G peak acceleration(11 ms duration), follow IEC 60068-2-27
	Vibration	Operating Random Vibration Test 5~500Hz,1Grms@with HDD;2Grms@with SSD, follow IEC 60068-2-64
	EMC	CE/FCC Class A
	Front Panel Protection	Front panel IP65 compliant

# IDD21190 & IDD22190 & IDD24190

## Technical Drawings unit:mm

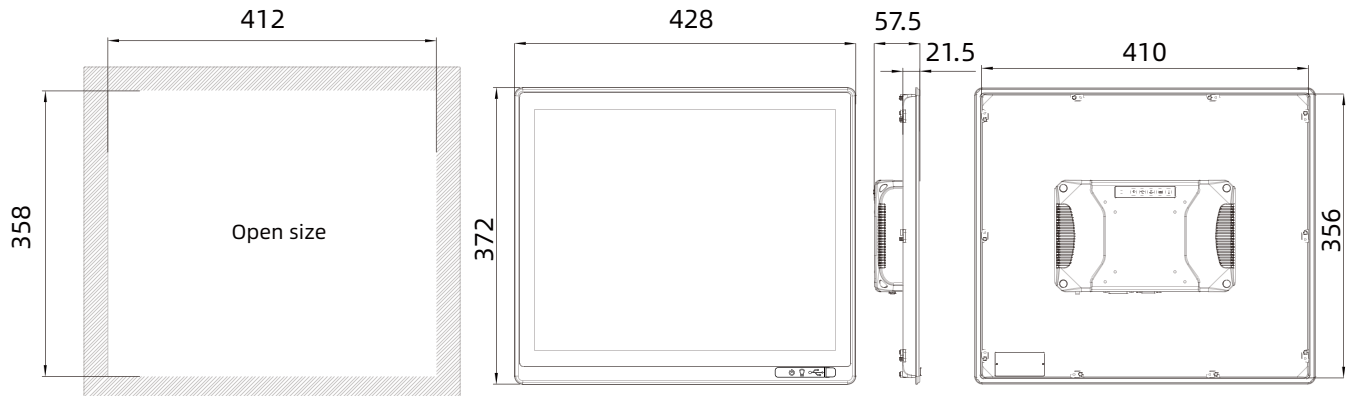

Panel Cutout Dimensions: 412 x 358mm (16.22 x 14.09in)

## External I/O View

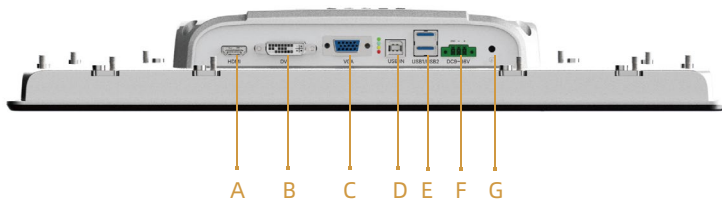

### Interface definition:

- A: HDMI
- B: DVI
- C: VGA
- D: USB input
- E: USB output
- F: DC 9~36V
- G: GND

## Ordering Information

Part Number	Description
IDD21190	19" TFT LCD / Resistive touch screen / DC9~36V Input / Resolution 1280x1024
IDD22190	19" TFT LCD / Capacitive touch screen / DC9~36V Input / Resolution 1280x1024
IDD24190	19" TFT LCD / Non-touch screen / DC9~36V Input / Resolution 1280x1024

## Optional Accessories

VGA	VGA 3m / 5m
DVI	DVI 3m / 5m / 8m / 10m
USB	USB 3m / 5m / 10m
HDMI	HDMI 3m / 5m / 10m

## Packing List

Terminal	3 pin spring clamp terminal
----------	-----------------------------

Note: Package contents are subject to change without prior notice